

# SICATJMT<sup>+</sup>



## **SICAT JMT<sup>+</sup>** JAW MOTION ANALYSIS SYSTEM

Instructions for use – English

# Contents

<b>1</b>	<b>User information.....</b>	<b>4</b>
1.1	Manufacturer information.....	4
1.2	Configuration of the instructions for use.....	4
1.3	Used symbols.....	4
<b>2</b>	<b>Area of use and safety.....</b>	<b>6</b>
2.1	Intended use.....	6
2.1.1	Use.....	6
2.1.2	SICAT data export.....	7
2.2	Safety.....	7
2.2.1	Environmental conditions.....	7
2.2.2	Storage and transport.....	7
2.2.3	Obligations of the user.....	8
2.2.4	General safety information.....	8
2.2.5	Safety information on heart pacemakers / defibrillators.....	9
2.2.6	Prohibited use.....	10
<b>3</b>	<b>Product description.....</b>	<b>11</b>
3.1	System components.....	11
3.2	Technical data of the SICAT JMT+ measurement system.....	11
3.3	Measurement principle of the SICAT JMT+ jaw motion analysis system.....	11
3.4	Control elements and connections.....	12
3.5	Meaning of the display lights.....	14
3.6	Assignment of the connecting sockets.....	15
3.7	Accessories and spare parts.....	16
<b>4</b>	<b>Putting the measurement system into operation.....</b>	<b>20</b>
4.1	Power supply and charging the battery.....	20
4.2	Computer requirements.....	20
4.3	Installing the SICAT JMT+ software.....	21
4.4	Connecting the accessory parts.....	21
4.5	Taking the measurement system out of operation.....	22
<b>5</b>	<b>Functional checks, preparation, disposal.....</b>	<b>23</b>
5.1	Specified regular checks and technical safety checks.....	23
5.2	Checking the measurement function.....	24
5.3	Rectifying faults.....	24
5.4	Preparation methods.....	25
5.4.1	Manual cleaning.....	25
5.4.2	Manual disinfection.....	26
5.4.3	Sterilization.....	26
5.5	Disposal.....	26
5.5.1	Packaging.....	26
5.5.2	Disposal of electronic waste.....	27
5.5.3	Accumulators and batteries.....	27
<b>6</b>	<b>Safety standards and classification of the system.....</b>	<b>28</b>

6.1	Classification pursuant to appendix IX of the Directive 93/42/EEC.....	28
6.2	Safety of electrical medical devices.....	28
6.2.1	Connection of the SICAT JMT+ measurement system with other electrical devices.....	28
6.2.2	Environment of the patient / test person.....	29
6.3	Electromagnetic compatibility for guidelines / manufacturer declaration.....	29
	<b>Glossary.....</b>	<b>34</b>
	<b>Index.....</b>	<b>35</b>
	<b>Contact.....</b>	<b>36</b>

# 1 USER INFORMATION

## 1.1 MANUFACTURER INFORMATION

**SICAT GmbH & Co. KG**

Brunnenallee 6

53177 Bonn

Germany

Telephone +49 (0)228 / 854697-11

Email: softwaresupport@sicat.com

Internet: www.sicat.com

## 1.2 CONFIGURATION OF THE INSTRUCTIONS FOR USE

The instructions for use for the SICAT JMT+ jaw motion analysis system consist of two parts:

1. SICAT JMT+ system technical data and instructions for use
2. SICAT JMT+ instructions for use of the user software

The part SICAT JMT+ system technical data and instructions for use primarily contains information concerning the technical data and operation of the SICAT JMT+ system, as well as information on its safe operation in combination with the patient accessories such as the **SICAT Fusion Bite**. Information concerning accessory components is limited to key safety and maintenance measures and/or hygiene measures.

 <b>CAUTION</b>	The exact compliance with the information in both parts of the instructions for use is required for proper use.
---	---

## 1.3 USED SYMBOLS

 Green highlighting around the side of the instructions for use designates new information concerning product safety.



Warning instructions designate a potential danger to the health and safety of users and/or patients. The instructions explain the type of danger and how it can be avoided.

<b>NOTICE</b>	Notices designate a potential danger that can cause damage to the device. The instructions explain the type of danger and how it can be avoided.
---------------	--

**CE**0197 The CE mark with code number 0197 of the notified body TÜV Rheinland LGA Products GmbH confirms the conformity of the measurement system with guideline 93/42/EEC (Medical Devices Directive).



Symbol for manufacturer and date of manufacture



Type BF device corresponding to DIN EN 60601-1



USB connection



This symbol shows that pursuant to the Directive on Waste Electrical and Electronic Devices (2012/19/EU) and national legislation, a product cannot be disposed of via the household waste, and must be disposed of separately within Europe.



Symbol for RF transmitters (Bluetooth interface)

**REF**

Article number of the measurement system / accessory

**SN**

Serial number of the measurement system



An accessory that is intended for one-off use on a single patient during a single treatment.



Read the instructions for use, especially the safety information.

## 2 AREA OF USE AND SAFETY

### 2.1 INTENDED USE

Based on the lower jaw movements of the patient, the SICAT JMT<sup>+</sup> system calculates all the necessary parameters with the goal of a supporting diagnosis for the following indications:

- supporting diagnosis for treating a diseased mandibular joint
- supporting diagnosis for creating occlusal mouth-guards
- supporting diagnosis for creating dentures
- supporting diagnosis for aesthetically functional reconstruction with or without tooth implants
- supporting diagnosis for treating craniomandibular dysfunction (CMD)

The measurement system also enables the exporting of the gathered data for further processing with CAD/CAM or PACS systems.

The measurement system may only be used by trained dentists. The area of use is limited to dental systems. A measurement is carried out within 15 minutes and should not be applied in the case of open wounds in the oral and head area; it can be applied to patients who are over 10 years old and who are mentally capable of exactly following the instructions of the operator.

#### 2.1.1 USE

The SICAT JMT<sup>+</sup> system is an electronic recording system that is based on 3D ultrasound measurements. SICAT JMT<sup>+</sup> systems record the lower jaw movements of the patient in all degrees of freedom.

The 3D presentation of the positions and movement paths of occlusal or juxta-articular measurement points provides important information on the movement behavior of the mandibular joint and the teeth on the lower and/or upper jaw. The 3D presentation of distinctive positions in the face provides a mapping of the face symmetry for the fitting of the denture. In a functional, preliminary examination, any discoordinations and limitations of movement can be analyzed and documented.

The electronic position analysis of the condyles enables different occlusion positions to be compared and can thereby indicate possible pain vectors in the joint.

An analysis of the chewing movements takes place with a special software module. The XML export function enables the use of jaw movements determined with the SICAT JMT<sup>+</sup> system in CAD/CAM systems and PACS systems for the functional optimization of dentures and of mouth-guards.

The measurement system may only be used by trained personnel, meaning dentists in dental facilities.

The SICAT JMT<sup>+</sup> system is used to support the functional diagnosis. The measurement sensor technology consists of a receiving sensor and a transmitting sensor. This is attached to the patient's head. The lower jaw sensor technology is fitted with a special locking mechanism for fixing it to the attachment. The face bow is positioned at the front with the support on the nasion and at the back of the head above the ears. A measurement can then be carried out according to the required settings and measurement parameters in the software.

All the measurement and/or analysis results of the SICAT JMT<sup>+</sup> system should always be interpreted by a trained specialist and checked for their relevance in consideration of the clinical medical history of the patient and in the context of the further diagnostic procedure. If invasive measures are taken, the measurement system should only be used as an additional assessment method. Under no circumstances can or should invasive surgery or measures that put the patient at risk be carried out based on the measurement results alone.

## 2.1.2 SICAT DATA EXPORT

The XML export function enables the use of jaw movements determined with the SICAT JMT<sup>+</sup> system in CAD/CAM systems and PACS systems for the functional optimization of dentures and of mouth-guards. The **SICAT Fusion Bite** serves as an interface for the referencing. It carries reference marks that can be captured by imaging systems such as surface scanners or DVT.

## 2.2 SAFETY

### 2.2.1 ENVIRONMENTAL CONDITIONS

The SICAT JMT<sup>+</sup> jaw motion analysis system is suitable for use in dry interior rooms, as can be found in clinics, medical practices and laboratories.

Permissible operating temperature: 10°C to 40°C

Relative humidity: 30 % to 70 %



The device should not be operated in wet zones, damp areas (swimming baths, saunas) or climatic chambers.

The measurement systems are not intended for use in areas where there is a risk of explosion, rooms used for medical purposes or in a flammable atmosphere (oxygen-enriched).

The devices should not be used near engines or transformers with a big connected load, for example, or heavy current power lines, as electrical or magnetic interference fields can distort the correct measurements and/or make them impossible.

To avoid reciprocal faults from occurring, two SICAT JMT<sup>+</sup> systems should never be operated in the same room or near other ultrasound emitting devices (e.g. ultrasonic cleaners, bird scare devices, alarm systems), as this can cause the measured values to be falsified.

### 2.2.2 STORAGE AND TRANSPORT

The storage and transport of the measurement system should only be carried out in the original packaging, as provided by SICAT.

Storage temperature: -20°C to +70°C

Relative humidity: 5% to 90%

Air pressure: 700 hPa to 1060 hPa

### 2.2.3 OBLIGATIONS OF THE USER



- The general guidelines and/or national legislation, national regulations and technical regulations pertaining to medical products are to be applied and fulfilled both with the start-up and during the operation of the SICAT product appropriate to the stated purpose. In Germany, operators, those responsible for such devices, and users are obliged to operate their devices in compliance with the MPG (Medical Devices Act) regulations.
- It is the obligation of the user:
  - to comply with all the safety instructions stated in the instructions for use.
  - to carry out all of the inspection and maintenance work regularly as specified in the instructions for use.
  - to only use fault free working equipment.
  - to ensure that the device is functionally safe and in a proper state prior to every instance of use of the device.
  - to ensure all the provided instructions for use that form part of the measurement system, are accessible to all users at all time, and to keep them near the measurement system.
  - to protect oneself, the patients and third parties against dangers.
  - to prevent a contamination occurring due to the product.
- During use, it is necessary to comply with the legal regulations, especially:
  - the current work safety regulations.
  - the current accident prevention measures.
- Responsibility is assumed to ensure the safety, reliability and effective performance of all measurement systems and accessories delivered by SICAT, such that:
  - assembly work, extensions, new settings, changes or repairs are carried out by SICAT or third parties authorized by SICAT, trained technicians or by the personnel of authorized dealers. The storage and transport should only be carried out in the original packaging, as provided by the manufacturer.
  - the product is operated in compliance with the instructions for use.
  - the information technology components provided by the operator comply with the technical requirements for hardware and software contained in these instructions for use, and that they are installed and set up according to the applicable descriptions for these components.
  - the place of installation corresponds with the specified environmental conditions for the measurement system and the current installation regulations.
  - only the software made available by SICAT, as well as the components and accessory parts listed in these instructions for use are used with the system.

### 2.2.4 GENERAL SAFETY INFORMATION



- The use and operation of the system and the evaluation of measurement data and its interpretation should only be carried out by trained specialist personnel. The manufacturer assumes no liability for damage to persons or property, or the loss of data that may occur due to the improper use of the software, the device, or its accessory parts.
- Patients and measurement data may only be copied, moved or deleted with the help of the database function that is provided by the SICAT application program. In the case of the deliberate changing of data without the database functions, the user alone bears the full risk.
- All measurement and/or analysis results should always be interpreted by a trained specialist and checked for their relevance in consideration of the clinical medical history of the patient and in the context of the further diagnostic procedure. If invasive measures are taken, the measurement system



should only be used as an additional assessment method. Under no circumstances can or should invasive surgery or measures that put the patient at risk be carried out based on the measurement results alone.

- In the case of malfunctions and/or defects being suspected and/or ascertained, the device has to be taken out of use immediately, labelled as 'Out of Use', and secured to prevent use. Please contact the manufacturer or your sales partner immediately under all circumstances.
- The measurement system has to be checked to ensure the measurement function is operating correctly at regular intervals. For further information about this, please see the *Functional checks, preparation, disposal* [► Page 23] chapter in these instructions for use.
- Do not install the jaw motion analysis system near a source of heat or in direct sunlight behind a window, as excessive heating can lead to incorrect measurement results.
- Ensure that all power and connection cables are routed and protected so that nobody is able to trip over them. Check all cables and connection plugs regularly for damage. Damaged power supply units, plug connectors and cables must be replaced before further use.
- The measurement system is not protected against the penetration of fluids. If fluid penetrates the measurement system, switch it off and please contact the SICAT GmbH & Co. KG technical service team.
- Never introduce objects into components of the measurement system.
- Before starting every measurement, it is necessary to ensure the correct choice and correct position of the transmitters or application aids. The cables or the application aids can present a risk of injury to the patient. In this context, please consult the special instructions in the handbooks of the application software, and do not allow children or mentally impaired patients to enter the proximity of the device without supervision.

## 2.2.5 SAFETY INFORMATION ON HEART PACEMAKERS / DEFIBRILLATORS



- In the magnetic coupling for the attachment of the **Lower jaw sensor type 24T** on the **Para-occlusal attachment 90** there are strong permanent magnets, such as those that are used on headphones on MP3 players. Under especially unfavorable circumstances, at short distances (< 15 cm), these magnets can have a negative impact on the functionality of certain implanted heart pacemakers and defibrillators. Therefore, the **Lower jaw sensor type 24T** should not be positioned on the upper body of the patient on patients with electronic implants.
- Version BT devices contain a Bluetooth transmitter as an interface to the PC. Although there is so far no evidence of a possible interference of heart pacemakers/defibrillators by Bluetooth transmitters, the SICAT JMT<sup>+</sup> system is not recommended to be used **on patients with electronic implants using the lanyard, but with the maintaining of a safety distance of at least 15 cm from the patient's thorax.**
- No interference of electronic implants is to be expected from the ultrasonic transmitters used in the measurement system, as the SICAT JMT<sup>+</sup> system works with airborne sound and a very low sound power of a few milliwatts. Due to the adverse connection during the transition from the air into the human body, the noise intensity of the measurement signals is weakened strongly such that any interference with implants, as well as any damage to tissue, is excluded.

## 2.2.6 PROHIBITED USE



- Improper and/or prohibited use of the measurement system is not permitted and express warning is herewith provided of such.
- Do not under any circumstances attempt to maintain or prepare the measurement system in any way other than as described in the instructions for use. This could cause the high sensitivity sensor technology to be in impaired terms of its measurement accuracy.
- In the case of malfunctions and/or defects being suspected and/or ascertained, the device has to be taken out of use immediately, labelled as 'Out of Use', and secured to prevent use, with the on/off switch being covered and secured with adhesive tape.
- Changing or modifying the measurement system or its accessory parts without the written permission of SICAT is not allowed. If the device is changed without permission, the operator is obliged to carry out suitable examinations and inspections in order to guarantee the secure use.
- SICAT measurement systems must not be operated in environmental conditions other than those stated in the *Technical data of the SICAT JMT<sup>+</sup> measurement system* [[▶ Page 11](#)] chapter (e.g. in an oxygen enriched environment, wet zones, damp rooms, climactic chambers, low pressure-, high pressure-, or altitude chambers, etc.).

## 3 PRODUCT DESCRIPTION

### 3.1 SYSTEM COMPONENTS

In the basic configuration, the SICAT JMT<sup>+</sup> system consists of the following components:

- **SICAT JMT<sup>+</sup> basic unit**
- **Lower jaw sensor type 24T** (transmitter)
- **Facebow type 13R** (receiver)
- **USB power supply** for supplying the measurement system for BT devices
- **USB adapter for SICAT JMT<sup>+</sup>** (type A to bayonet connector, 3 m in length)
- SICAT JMT<sup>+</sup> application software

### 3.2 TECHNICAL DATA OF THE SICAT JMT<sup>+</sup> MEASUREMENT SYSTEM

VERSION	SICAT JMT <sup>+</sup> BT
Dimensions (W x H x D)	111 x 86 x 31 mm
Weight	205 g
Power supply	5V DC / 1W (USB to charge battery)
Battery	yes
Measurement range	60 - 120 mm
Ultrasonic frequency	40 kHz
Max. measurement rate	50 Hz
Positioning accuracy in the occlusal area	± 0.1 mm (y); ± 0.2 mm (x, z)
Interface	USB
Bluetooth	yes

### 3.3 MEASUREMENT PRINCIPLE OF THE SICAT JMT<sup>+</sup> JAW MOTION ANALYSIS SYSTEM

The jaw motion analysis system consists of the **Lower jaw sensor type 24T** and the ultrasonic receiver module on the **Facebow type 13R**. The sensor technology components of the receiver and transmitter modules are each attached in geometrically defined positions. The marking points consist of small, sequentially operated ultrasonic transmitters. The accompanying facebow consists of six ultrasonic microphones. Both modules are connected with the evaluation electronics in the **SICAT JMT<sup>+</sup> basic unit** via a connecting cable.

During operation, the ultrasonic transmitters continuously emit impulses, from the operating time of that, between the transmitter and receiver microphones, the evaluation electronic calculates the absolute room coordinates of the markers using a triangulation method.

The calculation of the measurement coordinates and further measurement parameters, as well as the compensation of the disturbance variables, occurs on a PC-supported basis in the evaluation programs.

### BLOCK DIAGRAM OF THE MEASUREMENT SYSTEM

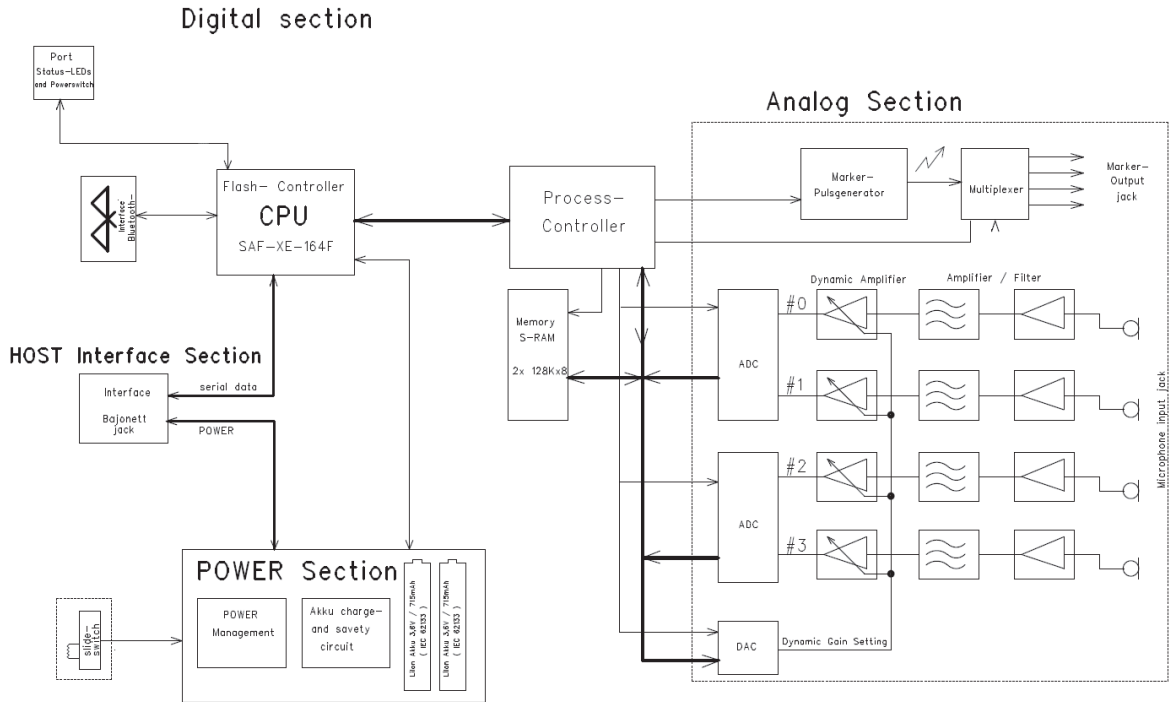

## 3.4 CONTROL ELEMENTS AND CONNECTIONS

### VIEW FROM FRONT



- 1** Facebow type 13R
- 2** Lower jaw sensor type 24T

## VIEW FROM SIDE



- 1 On/off switch

## VIEW FROM ABOVE

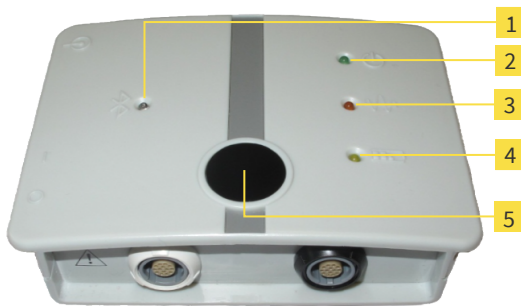

- 1 Bluetooth (blue)
- 2 Operating display (green)
- 3 Measurement (orange)
- 4 Power supply/battery (yellow)
- 5 IR-sync

## VIEW FROM BELOW

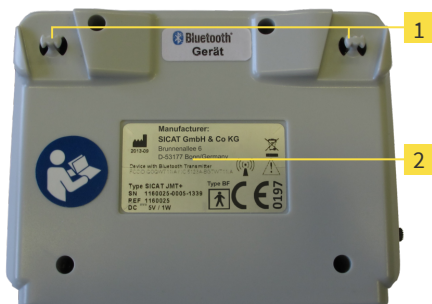

- 1 Bracket for **white lanyard**
- 2 Name plate

### 3.5 MEANING OF THE DISPLAY LIGHTS

LED	ON/OFF SWITCH	MEANING
Green / operational status indicator		
off	0 (off)	The measurement system is NOT in operation
lit up	1 (on)	The measurement system is in operation
Orange / measurement		
off	1 (on)	The measurement system is initialized and is ready for measurement.
flashes	1 (on)	The measurement system is waiting for initialization, measurement not possible yet.
lit up	1 (on)	The measurement has started / ultrasonic transmitters are active.
Yellow / battery charging status		
off	1 (on)	<b>USB adapter for SICAT JMT+</b> and/or <b>USB power supply</b> connected, reduced charging as soon as charging status > 95%
flashes	0 (off)	<b>USB adapter for SICAT JMT+</b> and/or <b>USB power supply</b> connected, battery charging, charging status < 95%
	1 (on)	Battery level critical < 20%  Connect the <b>USB adapter for SICAT JMT+</b> or <b>USB power supply</b> immediately, as it is possible that data will be lost if the measurement is continued.
lit up	0 (off)	<b>USB adapter for SICAT JMT+</b> and/or <b>USB power supply</b> connected, battery fully charged, charging status 100%
Blue / Bluetooth connection		

LED	ON/OFF SWITCH	MEANING
off	I (on)	The measurement system is initialized and is ready for measurement.
lit up	I (on)	The measurement has started / the measurement system is connected with the PC via Bluetooth

### 3.6 ASSIGNMENT OF THE CONNECTING SOCKETS

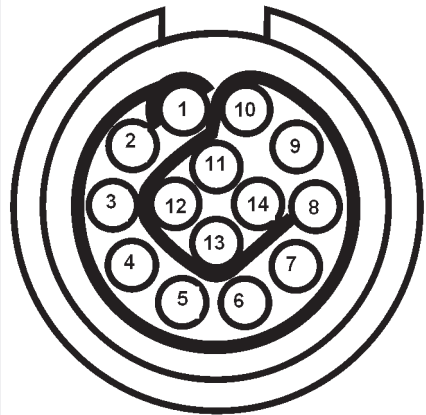

#### LOWER JAW SENSOR TYPE 24T / DIGITAL INPUT (LIGHT GREEN)

	SIGNAL	PIN
	Marker 1	Pin 1
	Marker 2	Pin 2
	Marker 3	Pin 3
	Marker 4	Pin 4
	SSWBus	Pin 5
	n.c.	Pin 6
	SDA (I <sup>2</sup> C)	Pin 7
	Signal	Pin
	SCL (I <sup>2</sup> C)	Pin 8
	+3.3 Volt	Pin 9
	DRY_A	Pin 10
	DRY_G	Pin 11
	Dig. Input	Pin 12
	GND	Pin 13
GND	Pin 14	

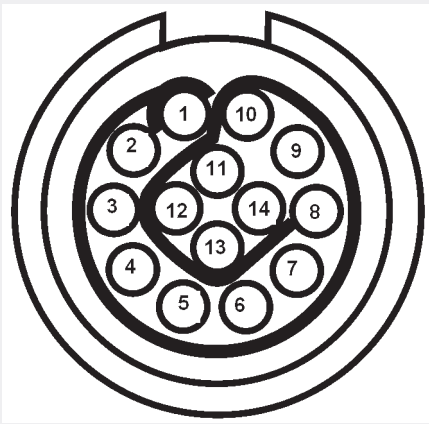





## FACEBOW TYPE 13R / DIGITAL INPUT (WHITE)

	SIGNAL	PIN
	Microphone 1	Pin 1
	Microphone 2	Pin 2
	Microphone 3	Pin 3
	Microphone 4	Pin 4
	SSWBus	Pin 5
	Mic-select	Pin 6
	SDA (I <sup>2</sup> C)	Pin 7
	SCL (I <sup>2</sup> C)	Pin 8
	+3.6 - 12 Volt	Pin 9
	DRY_A	Pin 10
	DRY_G	Pin 11
	Dig. Input	Pin 12
	GND	Pin 13
	GND	Pin 14

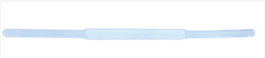

### 3.7 ACCESSORIES AND SPARE PARTS

NAME	FIGURE
<p><b>SICAT JMT+ basic unit</b></p> <p>for battery operation with Bluetooth interface</p>	
<p><b>Facebow type 13R</b></p> <p>for <b>SICAT JMT+ basic unit</b></p> <p>Complete with <b>Nasion support</b>, <b>Elastic neckband white</b>, and <b>Headband white</b></p>	



NAME	FIGURE
<p><b>Nasion support</b> suitable for <b>Facebow type 13R</b></p>	
<p><b>Bearing seat</b> suitable for <b>Facebow type 13R</b></p>	
<p><b>Bearing cushion gray</b> suitable for <b>Bearing seat</b> Packaging unit 5 pieces</p>	
<p><b>Nose cushion gray</b> Packaging unit 5 pieces</p>	
<p><b>Elastic neckband white</b> Packaging unit 5 pieces</p>	
<p><b>Headband white</b></p>	
<p><b>Lanyard white</b></p>	
<p><b>Lower jaw sensor type 24T</b> for <b>SICAT JMT+ basic unit</b></p>	

NAME	FIGURE
<p><b>Para-occlusal attachment 90</b></p> <p>for attachment to the front teeth</p> <p>L = 60 mm / W = 90 mm, medical steel, sterilizable</p> 	
<p><b>SICAT Fusion Bite</b></p> <p>made from LEXAN, suitable for gas and steam sterilization</p> <p>Hint: single use item, not intended for multiple use</p> 	
<p><b>SICAT Fusion Bite Adapter</b></p> <p>for attachment of the <b>Lower jaw sensor type 24T</b> to the <b>SICAT Fusion Bite</b></p>	
<p><b>USB power supply</b></p> <p>for charging the <b>SICAT JMT+ basic unit</b></p>	
<p>EU - Adapter <b>USB power supply</b></p> <p>UK - Adapter <b>USB power supply</b></p> <p>USA - Adapter <b>USB power supply</b></p> <p>Australia - Adapter <b>USB power supply</b></p> <p>World - Adapter <b>USB power supply</b></p>	

NAME	FIGURE
<p><b>USB adapter for SICAT JMT+</b></p> <p>Data connection of measurement system and PC</p>	
<p><b>SICAT JMT+ USB card</b></p> <p>Medium that contains the SICAT JMT+ software</p>	

## 4 PUTTING THE MEASUREMENT SYSTEM INTO OPERATION

For the commissioning of the jaw motion analysis system, a USB cable, as well as the medium with the SICAT JMT+ application software are required. All components are included in the scope of delivery for the SICAT JMT+ system.

### 4.1 POWER SUPPLY AND CHARGING THE BATTERY

For the rapid charging of the battery of the **SICAT JMT+ basic unit** when it is in the deactivated state, connect the **USB power supply** with an AC outlet and a USB cable with the USB socket on the **SICAT JMT+ basic unit**.

Alternatively, the **SICAT JMT+ basic unit** can also be charged or operated directly on the USB socket of a PC. To do this, connect the PC directly using a USB cable.



Only connect the **USB power supply** that is approved and supplied by SICAT, and arrange the measurement system such that the plug for the power socket is easily accessible at all times and the device can be easily disconnected from the mains.



**NOTICE**

Before connecting the **USB power supply** to the mains, consult the name plate information on the **USB power supply**, checking that the voltage and frequency is consistent with the local data. Only connect if such consistency is given.



Carry out a full visual inspection to the **USB power supply**, power cable and plug, as well as the protective contacts before the connection and/or operation of the measurement system. Damaged power supply units, cables or plug connectors must be replaced immediately by an authorized person.

### 4.2 COMPUTER REQUIREMENTS

For the requirements of the SICAT JMT+ system with concern to a PC/laptop, please refer to the instructions for use on SICAT JMT+ software.



SICAT is unable to accept any liability for damage or functional errors that are caused by faulty software installation or unsuitable computer hardware. If the operator installs additional hardware or third party software, this occurs based on the sole responsibility of the operator and is not covered by the manufacturer's liability. The computer needs to be CE-marked and needs to satisfy the requirements of DIN EN 60950 and/or DIN EN 60601-1.



The SICAT JMT<sup>+</sup> system is not intended for operation in a network/data pool. Connecting the system to a network/data pool can cause unforeseen risks to the patient and third parties. If the database of the SICAT JMT<sup>+</sup> software is installed in a network/data pool, the operator is obliged to ascertain, analyze, evaluate and manage all of the associated risks. In this context, the aspects of data protection, virus safety, updates to the operating system and regular backups are of particular importance. The risk assessments also have to include the subsequent changes to the network/data pool, such as updates/upgrades to devices and components that are connected with the network.

### 4.3 INSTALLING THE SICAT JMT<sup>+</sup> SOFTWARE

Installation instructions are provided in the instructions for use on the SICAT JMT<sup>+</sup> software.

#### NOTICE

Please make sure under all circumstances, that before connecting the measurement system and PC with the USB cable and/or via Bluetooth that you have installed the SICAT JMT<sup>+</sup> software.

If this step is omitted, problems can occur during the installation of the device driver, as the Windows operating system registers the location of the driver on the hard disk on the occasion of the first connection of the SICAT JMT<sup>+</sup> system and the PC.

If no corresponding SICAT JMT<sup>+</sup> software is installed on the PC yet, the mapping of the driver will fail for the above reasons, and the SICAT JMT<sup>+</sup> system may not function correctly.

#### NOTICE

If problems should occur with the hardware driver of the SICAT JMT<sup>+</sup> system, please unplug the USB cable from the PC and start it again. Now, re-install the SICAT JMT<sup>+</sup> software and create the connection once again.

### 4.4 CONNECTING THE ACCESSORY PARTS

Connect the **Facebow type 13R** and **Lower jaw sensor type 24T** with the corresponding colored sockets on the **SICAT JMT<sup>+</sup> basic unit**. (Images see *Control elements and connections* ► Page 12)

#### NOTICE

When connecting the **Facebow type 13R** and **Lower jaw sensor type 24T** to the **SICAT JMT<sup>+</sup> basic unit**, please ensure that the plugs are protected against false polarity / being plugged into the wrong socket with a keying nose. All of the plugs should go into the sockets easily and without much effort.

Next, connect the **SICAT JMT<sup>+</sup> basic unit** and a USB interface on your computer with the USB cable provided, or set up the Bluetooth connection. In this context, it is necessary to ensure that the measurement system is switched on. Your measurement system is now ready to use. Detailed instructions on the operation of the SICAT JMT<sup>+</sup> system are provided in the instructions for use for the SICAT JMT<sup>+</sup> software.

## 4.5 TAKING THE MEASUREMENT SYSTEM OUT OF OPERATION

To take the measurement system out of operation, please start by connecting the SICAT JMT+ software, shutting the PC down, and switching it off. Next, switch the **SICAT JMT+ basic unit** off and decouple the USB connection from the PC or **USB power supply**. Next, unplug the **USB power supply** from the socket.

## 5 FUNCTIONAL CHECKS, PREPARATION, DISPOSAL



- Regular maintenance and care of the measurement system helps to prevent damage and guarantees its long-term safety. All of the procedures stated in these instructions for use regarding the maintenance and preparation of the system are to be carried out on a regular basis.
- If the measurement system or accessory parts show damage, they should be sent to the manufacturer for a safety inspection. In the case of malfunctions and/or defects being suspected and/or ascertained, the device has to be taken out of use immediately, labelled as 'Out of Use'.
- All maintenance and servicing work on the measurement system or individual parts that are extended beyond the activities described in the instructions for use may only be completed by SICAT or persons authorized by SICAT.
- Before beginning the preparation, switch the measurement system off under all circumstances and disconnect it completely from the power supply network.

### 5.1 SPECIFIED REGULAR CHECKS AND TECHNICAL SAFETY CHECKS



- SICAT GmbH & Co. KG does not specify any technical safety checks for the SICAT JMT<sup>+</sup> system.
- To maintain the proper status of the electrical operating equipment, it is necessary to carry out repeated inspections and technical safety checks (e.g. in Germany according to BGV A3 accident prevention regulations as well as technical safety checks pursuant to the German Medical Products Operator Ordinance). In this context, it is necessary to ensure that these are not SICAT -specific measures, but the current regulations regarding electrical devices.
- For safety reasons, inspecting the proper state of all the connection cables, network cables, **USB power supply** and power sockets is recommended before every use of the measurement system. If parts are damaged it is necessary to replace them before using the measurement system again.
- Immediate servicing measures are to be carried out by SICAT if:
  - any liquids/fluids entered the device.
  - the cables or plug connectors show any damage.
  - parts of the sensor technology are damaged.
  - covers are damaged or have come off.
  - a defect or fault is either suspected or ascertained.
- If the name plate or other labelling (e.g. warning notices) on the machine are damaged or unreadable, these are to be replaced.

## 5.2 CHECKING THE MEASUREMENT FUNCTION



To guarantee long-term patient safety, the SICAT JMT<sup>+</sup> system has to be inspected at regular intervals to ensure its proper measurement function.

After hard knocks, such as if the **Facebow type 13R** or **Lower jaw sensor type 24T** should fall on the floor, it is necessary to check the measurement function immediately.

In the event of evident damage to system components (warping, dents, cracks), no further measurements should be carried out.

- The ultrasonic transmitters of the **Lower jaw sensor type 24T** can be inspected for their function during a measurement by listening to see whether a regular cracking is emitted from each of the transmitters.
- To inspect the system, for known jaw functioning measurements (e.g. known maximum opening width, known condylar range of motion with protrusion, known horizontal condylar guidance inclination), the user can measure himself with the measurement system. These measurement results should correspond with the known values.
- When the sensors do not move, the SICAT JMT<sup>+</sup> software should show an unmoving image of the lower jaw. Possible deviations (spikes or jumps in the measurement curve in spite of unmoved markers, incorrect presentation of the lower jaw, etc.) indicate a faulty measurement and impair the evaluation.
- Should doubts surround the measurement accuracy, inspecting the SICAT JMT<sup>+</sup> system at SICAT is recommended in order to ensure the stated measurement accuracy.

## 5.3 RECTIFYING FAULTS

In the event of faults, please start by checking the following points:

- Is the SICAT JMT<sup>+</sup> system switched on and being supplied with electricity? (green operating display LED is lit on the measurement system, batteries are charged or **USB power supply** and/or USB cable is connected)
- Has the USB connection and/or Bluetooth connection between the measurement system and measuring PC been made correctly?
- Are all the other components in the measurement system (**Facebow type 13R**, **Lower jaw sensor type 24T**) connected correctly?

### NOTICE

For further information on error messages and their rectification, please refer to the instructions for use on SICAT JMT<sup>+</sup> software.



## CHECK LIST FOR THE RECORDING OF ERROR MESSAGES

### NOTICE

To be able to provide you with the optimum support in the case of operational faults to your SICAT JMT<sup>+</sup> system, our service team employees require the following information:

- Serial numbers of the **SICAT JMT<sup>+</sup> basic unit** and **Lower jaw sensor type 24T/Facebow type 13R**
  - The serial numbers are on the name plates on the rear of the **SICAT JMT<sup>+</sup> basic unit** and/or on the cables for the **Facebow type 13R** and **Lower jaw sensor type 24T**.
- SICAT JMT<sup>+</sup> software version
- Operating system version of your measurement PC
  - e.g. Windows 7 Professional Service pack 1 (to find under Windows 7: **Windows Start button > Control Panel > System**)
- Further components connected to the measurement system
- List of all USB/Bluetooth devices connected to the measurement PC
  - e.g. mouse, printer, other measuring systems etc.
- Screen shot of the error message, or exact wording
  - e.g. "Timeout reading from USB"
- Accurate as possible description of the process that led to the error message
  - e.g. "Type A" measurement started, button "B" then clicked, movement "C" then completed, changed over to function "D", upon changing back, the error message "xyz" was reported, etc.

## 5.4 PREPARATION METHODS

### NOTICE

After every case of use of the SICAT JMT<sup>+</sup> system, a re-preparation is required according to DIN EN ISO 17664. All accessory parts that come into contact with the patient's mucosa have to be sterilized before use.

### CAUTION



Before starting cleaning work or disinfection, switch the measurement system off under all circumstances and disconnect it completely from the USB connection and the **USB power supply**.



The following accessory parts are only intended for one-off use on a patient, and should not be prepared again after use.

- **Para-occlusal attachment 90**
- **SICAT Fusion Bite**

### 5.4.1 MANUAL CLEANING

- Before sterilization, clean the accessory parts by hand under running water (drinking water quality, 30 °C ± 5 °C, flow rate 2 liters/min.) with a medium strength toothbrush for 30 seconds.
- Complete the sterilization immediately subsequent to the cleaning.
- The cleaning of measurement systems and electrical accessories (**Facebow type 13R, Lower jaw sensor type 24T**) should only be carried out when the system is switched off and the **USB power supply** and/or USB cable are unplugged, and using a damp cloth.

## 5.4.2 MANUAL DISINFECTION

The measurement system can be wipe-disinfected with suitable solutions. Disinfect all components with a cloth that has been dampened with a disinfectant solution.



**Do not use any spray disinfectants on the Facebow type 13R and the Lower jaw sensor type 24T!**

Spray disinfectants destroy the high accuracy measurement sensors.

## RECOMMENDED DISINFECTANT SOLUTION

Composition approx. 25% ethanol, 35% propanol

e.g. "Mikrozid "Liquid / Schülke & Mayr or comparable solutions

**NOTICE**

When using a disinfectant solution, please comply with the recommendations stated by the manufacturer, especially the specified application time.



Due to the risk of possible mix-ups, chemicals that are required for the disinfection or cleaning must only be stored, prepared and kept ready in their intended containers.

## 5.4.3 STERILIZATION

All accessory parts that come into contact with the patient's mucosa have to be sterilized before use.

**NOTICE**

The sterilization is to be completed immediately subsequent to the cleaning.

Sterilize the bite-forks and lower jaw attachment with a fractionated pre-vacuum for four minutes at  $134\text{ °C} \pm 1\text{ °C}$  and 3.04 bar (can be sterilized up to a max. of  $138\text{ °C}$ ).

It is necessary to sterilize the following accessory parts:

- **Para-occlusal attachment 90**
- **SICAT Fusion Bite**

## 5.5 DISPOSAL

### 5.5.1 PACKAGING

In Germany, all of the transport packaging supplied by SICAT can be disposed of into the materials cycle at local waste disposal centers.

## 5.5.2 DISPOSAL OF ELECTRONIC WASTE



The adjacent symbol shows that pursuant to the EC Directive on Waste Electrical and Electronic Devices (2012/19/EU) and national legislation, a product cannot be disposed of via the household waste, and must be disposed of separately within Europe.

For this purpose, at the end of its useful life, the measurement system can be returned by the customer to SICAT GmbH & Co. KG, and will then be forwarded by SICAT at no extra cost and without reimbursement to the appropriate recycling companies.

Due to potentially dangerous substances that can often be found in electrical or electronic devices, the improper handling of old devices can have a negative impact on the environment and human health. In disposing of this product properly, you also contribute to an effective use of natural resources.

## 5.5.3 ACCUMULATORS AND BATTERIES

Accumulators and batteries do not belong in the household waste! In the interests of protecting the environment, the end consumer is legally obliged (Battery Directive) to hand in old and used batteries. Used batteries and power packs can be handed in at the district collection points, or in all locations where such batteries are offered for sale. The batteries are accepted at no cost to the consumer.

## 6 SAFETY STANDARDS AND CLASSIFICATION OF THE SYSTEM

### 6.1 CLASSIFICATION PURSUANT TO APPENDIX IX OF THE DIRECTIVE 93/42/EEC

The system is classified as a medical product of **Class I with a measuring function**.

### 6.2 SAFETY OF ELECTRICAL MEDICAL DEVICES

The device fulfils the requirements of the DIN EN 60601-1:2006 standard.

Classification corresponding to DIN EN 60601-1

Type BF

Protection class II

Continuous operation

Not suitable for use in an oxygen-enriched environment

#### 6.2.1 CONNECTION OF THE SICAT JMT<sup>+</sup> MEASUREMENT SYSTEM WITH OTHER ELECTRICAL DEVICES

(also see DIN EN 60601-1:2006, section 16 Medical Electrical Systems)

  
**CAUTION**

The SICAT JMT<sup>+</sup> system may only be connected with other electrical devices if they correspond with the requirements of DIN EN 60950 and/or DIN EN 60601-1, or have been designated as compatible by SICAT GmbH & Co. KG.

  
**CAUTION**

When connecting several devices to a single measurement station, it is necessary to ensure that no dangers can occur due to the accumulation of leakage currents.

Devices with that the patient comes directly into contact, and that are used together in a single medical electrical system, must comply in complete form with all the requirements of DIN EN 60601-1:2006, section 11.

There is the risk of an electrical shock upon contact with devices that are not earthed separately.

## 6.2.2 ENVIRONMENT OF THE PATIENT / TEST PERSON

In practice, an experience value with a clearance of 1.5 m from the patient has proven effective for the determination of the patient environment.

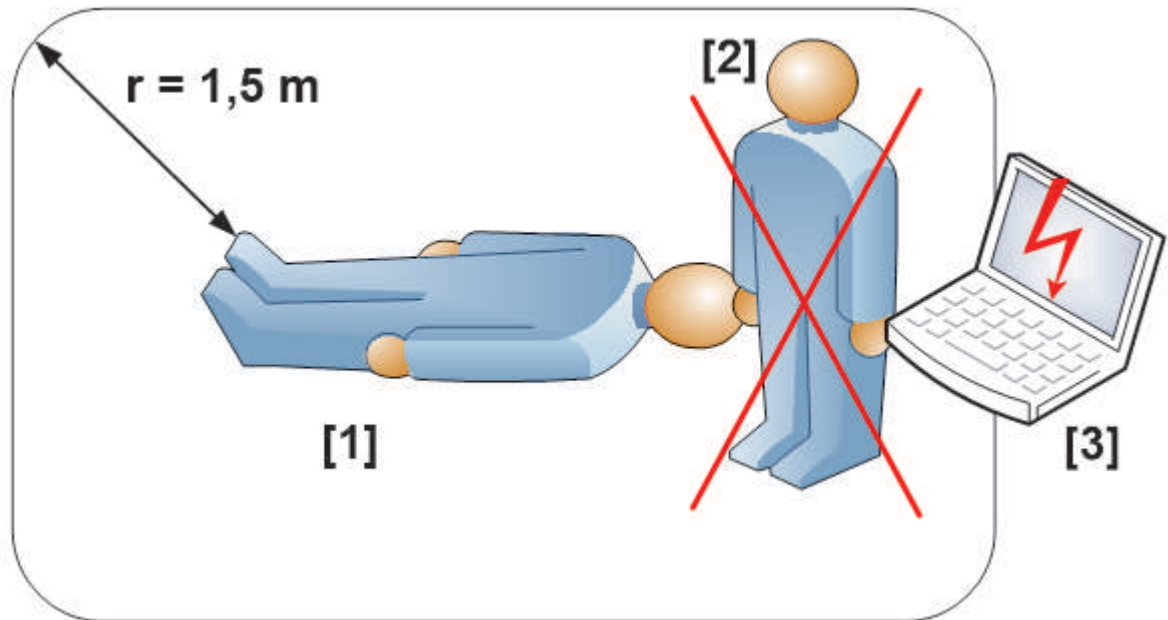

  
**CAUTION**

When operating the system, the user [2] must make sure that they never touch the PC [3] and the patient [1] at the same time. The same applies to all other non-medical electrical components that are only to be used outside the patient environment.

Furthermore, the user must also make sure that they never touch the contacts of the measurement system plug connectors and the patient at the same time. Failure to comply can lead to the occurrence of dangerous leakage currents.

The following components of the SICAT JMT<sup>+</sup> system may only be used within the patient environment:

- **SICAT JMT<sup>+</sup> basic unit** including sensor technology

  
**CAUTION**

The computer and other non-medical electrical accessories have to be set up outside of the patient environment (1.5 m clearance).

## 6.3 ELECTROMAGNETIC COMPATIBILITY FOR GUIDELINES / MANUFACTURER DECLARATION

The SICAT JMT<sup>+</sup> system satisfies the requirements of the EN 60601-1-2 standard. (Medical electrical devices - part 1-2: General concerning for safety including the key performance attributes - supplementary norm: Electromagnetic compatibility - requirements and tests).

Testing authority:

**Schulle Elektronik in Munich**

Produktions- und Vertriebs GmbH

Benzstrasse 1A

85551 Kirchheim

Detailed information on EMC values and manufacturer data is provided in the tables for this chapter of the instructions for use.

Medical electrical devices are subject to special safety measures regarding EMC (electromagnetic compatibility) and have to be installed and put into operation pursuant to the instructions provided below.

 **CAUTION** Although the SICAT JMT<sup>+</sup> system corresponds with the requirements of the DIN EN 60601-1-2 norm in terms of all points, mobile phones cannot be excluded from influencing the jaw motion analysis system. If possible, such devices should not be operated during measurements in the environment of the JMT measurement system.

 **CAUTION** The use of accessories, especially connection cables to the PC that are not supplied by SICAT for the SICAT JMT<sup>+</sup> system, or are expressly approved for use with the device, can lead the JMT systems to have increased emissions or reduced interference immunity.

 **CAUTION** The SICAT JMT<sup>+</sup> system should not be used near X-ray systems, engines or transformers with a big connected load, for example, as electrical or magnetic interference fields can distort the correct measurements and/or make them impossible. The same applies to neighboring power cables and devices that do not have CE marking. If operation is required in the immediate proximity of sources of interference, it is necessary to observe the device under all circumstances to make sure it is operating in the proper way in this arrangement.

**GUIDELINES AND MANUFACTURER'S DECLARATION - ELECTROMAGNETIC EMISSIONS**

The measurement systems in the JMT range of products are intended for operation in the electromagnetic environment stated below. The customer or user of the JMT measurement system should ensure that it is operated in such an environment.

<b>Emissions tests</b>	<b>Compliance</b>	<b>Electromagnetic environment - guideline</b>
RF emissions according to CISPR 11	Group 1	The measurement systems in the JMT range of products only use RF energy for their internal functioning. For this reason, their RF emissions are very low and it is unlikely that neighboring electronic devices will suffer interference.
RF emissions according to CISPR 11	Class B	The JMT measurement system is suitable for use in all facilities, including those in domestic settings and those directly connected to the public power supply network that supplies buildings that are used for domestic purposes.
Harmonic emissions according to IEC 61000-3-2	Class B	
Voltage fluctuations/flicker according to IEC61000-3-3	Compliance	

### GUIDELINES AND MANUFACTURER'S DECLARATION - ELECTROMAGNETIC INTERFERENCE IMMUNITY

The measurement systems in the JMT range of products are intended for operation in the electromagnetic environment stated below. The customer or user of the JMT measurement system should ensure that it is used in such an environment.

Immunity tests	IEC 60601- test level	Compliance level	Electromagnetic environment - guidelines
Electrostatic discharge (ESD) according to IEC 61000-4-2	± 6 kV contact discharge ± 8 kV air discharge	± 6 kV contact discharge ± 8 kV air discharge	Floors should be made from wood or concrete or fitted with ceramic tiles. If the floor is equipped with synthetic material, the relative air humidity should be at least 30%.
electrical fast transient/bursts according to IEC 61000-4-4	± 2 kV for power cables ± 1 kV for input and output cables	± 2 kV for power cables ± 1 kV for input and output cables	The supply voltage quality should be that of a typical commercial or hospital environment.
Surges according to IEC 61000-4-5	± 1 kV differential mode ± 2 kV common mode	± 1 kV differential mode ± 2 kV common mode	The supply voltage quality should be that of a typical commercial or hospital environment.
Voltage dips, short interruptions and voltage variations on the supply voltage according to IEC 61000-4-11	< 5% $U_T$ (> 95% drop to the $U_T$ ) for ½ a period 40% $U_T$ (60% drop to the $U_T$ ) for 5 periods 70% $U_T$ (30% drop to the $U_T$ ) for 25 periods < 5 % $U_T$ (> 95 % drop to the $U_T$ ) for 5 s	< 5% $U_T$ (> 95% drop to the $U_T$ ) for ½ a period 40% $U_T$ (60% drop to the $U_T$ ) for 5 periods 70% $U_T$ (30% drop to the $U_T$ ) for 25 periods < 5 % $U_T$ (> 95 % drop to the $U_T$ ) for 5 s	The supply voltage quality should be that of a typical commercial or hospital environment. If the user of the measurement systems in the JMT range of products requires continued functioning during power supply interruptions, it is recommended that the JMT jaw motion analysis system be powered by an interruption-free power supply or a battery.
Magnetic field with the power supply frequency (50/60 Hz) according to IEC 61000-4-8	3 A/m	3 A/m	Power frequency magnetic fields should correspond with the typical values that can be found in the commercial or hospital environment.

NOTE  $U_T$  is the A.C. mains voltage prior to application of the test level.

**GUIDELINES AND MANUFACTURER'S DECLARATION - ELECTROMAGNETIC INTERFERENCE IMMUNITY**

The measurement systems in the JMT range of products are intended for operation in the electromagnetic environment stated below. The customer or user of the JMT measurement system should ensure that it is used in such an environment.

Immunity tests	IEC 60601- test level	Compliance level	Electromagnetic environment - guidelines
Conducted RF surges according to IEC 61000-4-6	3 V <sub>eff</sub> 150 kHz to 80 MHz	3 V <sub>eff</sub>	<p>Portable and mobile radio equipment should be used no closer to the JMT measurement system, including the cables, than the recommended safety distance, calculated from the equation applicable to the frequency of the transmitter.</p> <p><b>Recommended safety distance:</b></p> $d = 1,2\sqrt{P}$
Radiated RF surges according to IEC 61000-4-3	3 V/m 80 MHz to 2.5 GHz	3 V/m	$d = 1,2\sqrt{P}$ for 80 MHz to 800 MHz $d = 2,3\sqrt{P}$ for 800 MHz to 2.5 GHz

Where P is the rated output of the transmitter in watts (W) according to the information of the transmitter manufacturer and d is the recommended safety distance in meters (m).

The field strength from fixed RF transmitters as determined by an electromagnetic site survey <sup>a</sup> is less than the compliance level in all frequency ranges. <sup>b</sup>

Interference may be possible in the vicinity of equipment that is marked with the following symbol





**GUIDELINES AND MANUFACTURER'S DECLARATION - ELECTROMAGNETIC INTERFERENCE IMMUNITY**

NOTE 1 At 80 MHz and 800 MHz, the higher value applies.

NOTE 2 These guidelines may not apply in all cases. Electromagnetic propagation is affected by absorption and reflection from buildings, objects and people.

a The field strengths of fixed transmitters, such as base stations for radio telephones and land mobile radios, amateur radio, AM and FM radio broadcasters and TV broadcasters, cannot be theoretically predicted with accuracy. To assess the electromagnetic environment due to the fixed RF transmitters, an electromagnetic site survey should be considered. If the measured field strength at the location of the JMT measurement system exceeds the aforementioned compliance level, the JMT measurement system should be observed to verify its proper functioning. If abnormal performance attributes are observed, additional measures can be necessary, such as re-orientation or an alternative location of the measurement system of the JMT range of products.

b Over the frequency range of 150 kHz to 80 MHz, the frequency range should be lower than 3 V/m.

**RECOMMENDED SAFETY DISTANCES BETWEEN PORTABLE AND MOBILE RF COMMUNICATION DEVICES AND THE MEASUREMENT SYSTEMS IN THE JMT RANGE OF PRODUCTS**

The measurement systems in the JMT range of products are intended for operation in an electromagnetic environment in that radiated RF interference is controlled. The customer or the user of the JMT measurement system can help prevent electromagnetic interference by maintaining a minimum clearance between portable and mobile RF communication devices (transmitters) and the JMT measurement system - depending on the output power of the communication device as stated below.

Rated output of transmitter W	Safety distance depending on the transmitter frequency		
	m		
	150 kHz to 80 MHz	80 MHz to 800 MHz	800 MHz to 2.5 GHz
	$d = 1,2\sqrt{P}$	$d = 1,2\sqrt{P}$	$d = 2,3\sqrt{P}$
0.01	0.12	0.12	0.23
0.1	0.38	0.38	0.73
1	1.2	1.2	2.3
10	3.8	3.8	7.3
100	12	12	23

For transmitters whose maximum rated output is not stated in the above table, the recommended safety distance d in meters (m) can be estimated using the equation applicable to the corresponding column, where P is the rated output of the transmitter in watts (W) according to the information of the transmitter manufacturer.

NOTE 1 At 80 MHz and 800 MHz, the higher frequency range applies.

NOTE 2 These guidelines may not apply in all cases. Electromagnetic propagation is affected by absorption and reflection from buildings, objects and people.

## *GLOSSARY*

### SICAT JMT<sup>+</sup>

---

SICAT JMT<sup>+</sup> records the motion of the lower jaw.

# INDEX

## C

Cleaning	
Manual cleaning	25
Manual disinfection	26
Sterilization	26

## D

Disposal	
Accumulators and batteries	27
Electronics	27
Packaging	26

## E

Export	7
--------	---

## I

Instructions for use	
Configuration	4
Used symbols	4
Intended use	6

## M

Maintenance	
Checking the measurement function	24
Functional checks, preparation, disposal	23
Preparation methods	25
Rectifying faults	24
Specified regular checks and technical safety checks	23
Manufacturer information	4
Measurement system	
Charging the batteries	20
Computer requirements	20
Connecting the accessory parts	21
Installing the SICAT JMT+ software	21
Power supply	20
Putting into operation	20
Taking out of operation	22

## P

Product description	
Accessories and spare parts	16
Assignment of the connecting sockets	15
Control elements and connections	12
Meaning of the display lights	14
Measurement principle of the SICAT JMT+ jaw motion analysis system	11
System components	11
Technical data of the SICAT JMT+ measurement system	11

## S

Safety	
Environmental conditions	7
General safety information	8
Heart pacemakers / defibrillators	9
Obligations of the user	8
Prohibited use	10
Storage and transport	7
Safety standards and classification of the system	
Appendix IX of the Directive 93/42/EEC	28
Connection of the SICAT JMT+ measurement system with other electrical devices	28
Electromagnetic compatibility for guidelines / manufacturer declaration	29
Environment of the patient / test person	29
Safety of electrical medical devices	28

## U

Use	6
-----	---

## CONTACT



### **Manufacturer**

SICAT GmbH & Co. KG

Brunnenallee 6

53177 Bonn, Germany

Telephone: +49 (0)228 / 85497-0

Fax: +49 (0)228 / 854697-99

Email: [info@sicat.com](mailto:info@sicat.com)

<http://www.sicat.com>

**C** **€**0197

Material number: 6467323

Change number: 119044

LAST UPDATE: 2014-08-12



# CONTACT



**Manufacturer**

SICAT GMBH & CO. KG

BRUNNENALLEE 6

53177 BONN, GERMANY

T +49 (0)228 / 854697-11

F +49 (0)228 / 854697-99

INFO@SICAT.COM

WWW.SICAT.COM

CE 0197

